

# EECS 16A Designing Information Devices and Systems I Homework 7

Spring 2021

**This homework is due March 12, 2021, at 23:59.**

**Self-grades are due March 15, 2021, at 23:59.**

## Submission Format

Your homework submission should consist of **one** file.

- `hw7.pdf`: A single PDF file that contains all of your answers (any handwritten answers should be scanned)

Submit the file to the appropriate assignment on Gradescope.

## 1. Reading Assignment

For this homework, please read Notes 13 and 14. Note 13 will refresh you on how simple 1-D resistive touchscreens work, as well as the notion of power in electric circuits. Note 14 will cover a slightly more complicated 2-D resistive touchscreens and how to analyze them from a circuits perspective.

- Describe the key ideas behind how the 1D touchscreen works. In general, why is it useful to be able to convert a “physical” quantity like the position of your finger to an electronic signal (i.e. voltage)?

## 2. [PRACTICE] It’s a Triforce!

**Learning Goal:** This problem explores passive sign convention and nodal analysis in a slightly more complicated circuit.

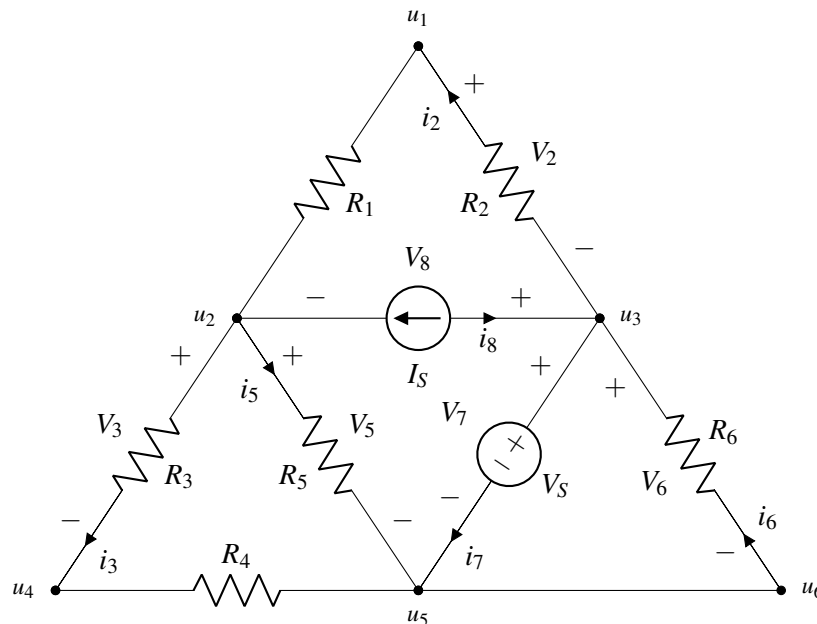

Figure 1: A triangular circuit consisting of a voltage source  $V_s$ , current source  $I_s$ , and resistors  $R_1$  to  $R_6$ .

- Which of the elements  $I_s$ ,  $V_s$ ,  $R_2$ ,  $R_3$ ,  $R_5$ , or  $R_6$  in Figure 1 have current-voltage labeling that violates Passive Sign Convention? There could be more than one possible element which violates Passive Sign Convention. Explain your reasoning.
- In Figure 1, the nodes are labeled with  $u_1$ ,  $u_2$ , ... etc. There is a subset of  $u_i$ 's in the given circuit that are redundant, i.e. there might be more than one label for the same node. Which node(s)? Justify your answer.
- Redraw the circuit diagram by correctly labeling all the element voltages and element currents according to passive sign convention. (The component labels that were violating Passive Sign Convention in part (a), should be corrected by swapping the element voltage polarity. Also, the elements that have not been labeled yet, should be labeled following Passive Sign Convention.)
- Write an equation to describe the current-voltage relationship for element  $R_4$  in terms of the relevant  $i$ 's,  $R$ 's, and node voltages in this circuit.
- Write the KCL equation for node  $u_2$  in terms of the node voltages and other circuit elements.

### 3. Circuit Analysis

**Learning Goal:** This problem will help you practice circuit analysis using NVA method.

Using the steps outlined in lecture or in Note 11, analyze the following circuits to calculate the currents through each element and the voltages at each node. Use the ground node labelled for you. You may use a numerical tool such as IPython to solve the final system of linear equations.

$$V_s = 5\text{ V}, I_s = 2\text{ A}, R_1 = R_2 = 2\Omega, R_3 = 4\Omega$$

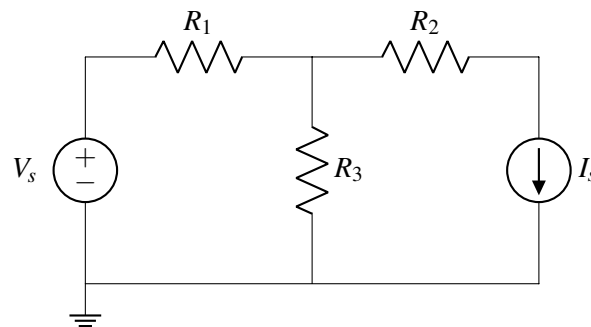

### 4. Power Analysis

**Learning Goal:** This problem aims to help you practice calculating power dissipation in different circuit elements. It will also give you insights into how power is conserved in a circuit.

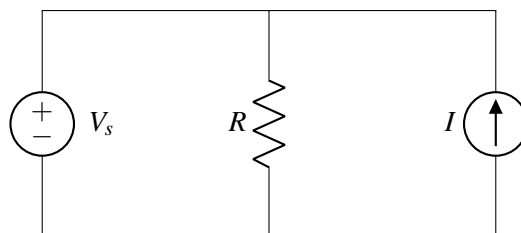

- Find the expressions of power dissipated by each element in the circuit above. Remember to label voltage-current pairs using passive sign convention.

- (b) Use  $R = 5\text{k}\Omega$ ,  $V_s = 5\text{V}$ , and  $I = 5\text{mA}$ . Calculate the power dissipated by the voltage source ( $P_{V_s}$ ), the current source ( $P_I$ ), and the resistor ( $P_R$ ).
- (c) Once again, let  $R = 5\text{k}\Omega$ ,  $V_s = 5\text{V}$ . What does the value  $I$  of the current source have to be such that the current source **dissipates**  $40\text{mW}$ ? Note that it is possible for a current source to *dissipate* power, i.e. under passive sign convention,  $P_I = 40\text{mW}$ . For this value of  $I$ , compute  $P_{V_s}$ ,  $P_I$ , and  $P_R$  as well.

*As an aside: If the current source were delivering power it would have been  $P_I = -40\text{mW}$ , under passive sign convention, but this is NOT what the question is asking about.*

## 5. Volt and ammeter

**Learning Goal:** This problem helps you explore what happens to voltages and currents in a circuit when you connect voltmeters and ammeters in different configurations.

Use the following numerical values in your calculations:  $R_1 = 1\text{k}\Omega$ ,  $R_2 = 2\text{k}\Omega$ ,  $R_3 = 3\text{k}\Omega$ ,  $R_4 = 4\text{k}\Omega$ ,  $R_5 = 5\text{k}\Omega$ ,  $V_s = 10\text{V}$ .

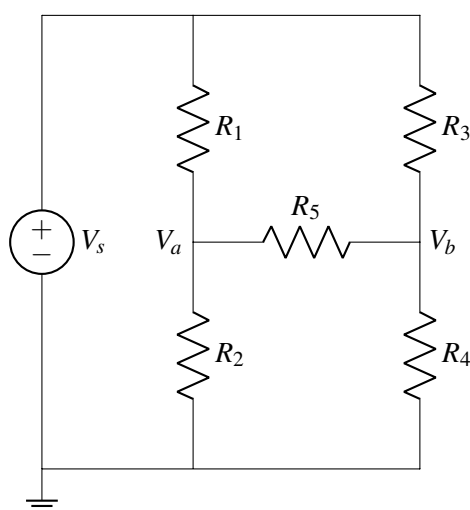

Figure 2: Circuit consisting of a voltage source  $V_s$  and five resistors  $R_1$  to  $R_5$

- (a) Redraw the circuit diagram shown in Figure 2 by adding a voltmeter (letter  $V$  in a circle and plus and minus signs indicating direction) to measure voltage  $V_{ab}$  from node  $V_a$  (positive) to node  $V_b$  (negative). Calculate the value of  $V_{ab}$ . You may use a numerical tool such as IPython to solve the final system of linear equations.
- (b) Suppose you accidentally connect an ammeter in part (a) instead of a voltmeter. Calculate the value of  $V_{ab}$  with the ammeter connected.
- (c) Redraw the circuit diagram shown in Figure 2 by adding an ammeter (letter  $A$  in a circle and plus and minus signs indicating direction) in series with resistor  $R_5$ . This will measure the current  $I_{R_5}$  through  $R_5$ . Calculate the value of  $I_{R_5}$ .
- (d) Your friend accidentally connects a voltmeter in part (c) above, rather than an ammeter. Calculate the value of  $I_{R_5}$  with the voltmeter connected.

## 6. Fruity Fred

**Learning Goal:** This problem will introduce the process of designing a sensing circuit for the purpose of measuring a physical quantity. This will also help to build your intuition for modeling physical elements.

Fruity Fred just got back from Berkeley Bowl with a bunch of mangoes, pineapples, and coconuts. He wants to sort his mangoes in order of weight, so he decides to use his knowledge from EECS16A to build a scale.

He finds two identical bars of material ( $M_1$  and  $M_2$ ) of length  $L$  (in meters) and a cross-sectional area (i.e. width  $\times$  thickness) of  $A_c$  (in meters<sup>2</sup>). The bars are made of a material with resistivity  $\rho$ . He knows that the **length of these bars decreases** by  $k$  meters per Newton of force applied, while the **cross-sectional area remains constant**.

He builds his scale as shown below, where the top of the vertical bars are connected with an ideal electrical wire. The left side of the diagram shows the scale at rest (with no object placed on it), and the right side shows it when the applied force is  $F$  (Newtons). The force  $F$  is equally distributed between two bars, causing the length of each bar to decrease by  $kF/2$  meters. Fred's mangoes are not very heavy, so the change in each bar's length is very small compared to the total length (mathematically, we can write this by using the "much smaller than" symbol  $\ll$ , i.e.  $kF/2 \ll L$ ).

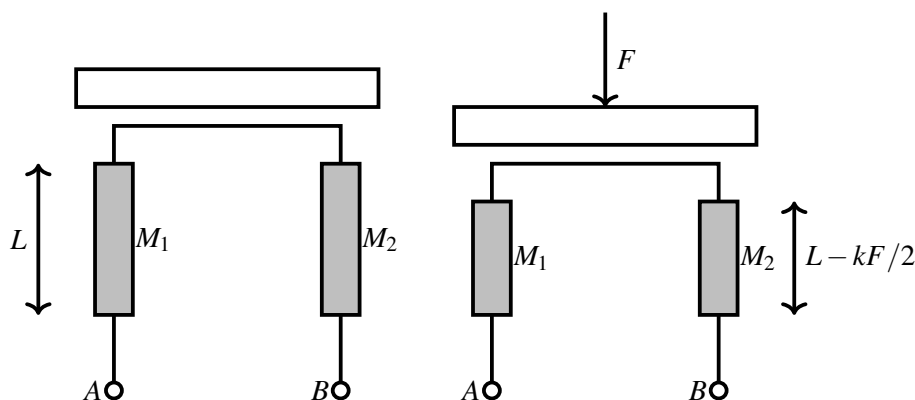

- (a) Let  $R_{AB}$  be the resistance between nodes  $A$  and  $B$  with the weights on the scale. Write an expression for  $R_{AB}$  as a function of  $A_c$ ,  $L$ ,  $\rho$ ,  $F$ , and  $k$ . *Hint: You can start by representing each bar as a resistor, then find how they are connected.*
- (b) Fred wants to measure a voltage that changes based on how much weight is placed on his scale. He knows that  $R_{AB}$  will change with the weight on the scale.

Design a circuit for Fred that outputs a voltage that is some function of the weight  $F$ . This function does *not* have to be linear. **Your circuit should include  $R_{AB}$ , and you may use any number of voltage sources and resistors in your design.** Be sure to **label** where the voltage should be measured in your circuit.

Also provide an **expression** relating the output voltage of your circuit to the force applied on the scale. This expression can contain any necessary parameters.

*Hint: If you connected only a voltage source across  $A$  and  $B$  and measured the voltage ( $V_{AB}$ ) between  $A$  and  $B$ , would  $V_{AB}$  change based on the value of  $R_{AB}$ ? It turns out it wouldn't. Why?*

*Hint: Consider tools we have learned in this class such as voltage dividers. Can you build a circuit using  $R_{AB}$  and  $R_{fixed}$ , where  $R_{fixed}$  is a value you know and choose?*

## 7. Resistive Touchscreen

**Learning Goal:** The objective of this problem is to provide insight into modeling of resistive elements. This will also help to apply the concepts from resistive touchscreen.

In this problem, we will investigate how a resistive touchscreen with a defined thickness, width, and length can actually be modeled as a series combination of resistors. As we know the value of a resistor depends on its length.

Figure 3 shows the top view of a resistive touchscreen consisting of a conductive layer with resistivity  $\rho_1$ , thickness  $t$ , width  $W$ , and length  $L$ . At the top and bottom it is connected through good conductors ( $\rho = 0$ ) to the rest of the circuit. The touchscreen is wired to voltage source  $V_s$ .

Use the following numerical values in your calculations:  $W = 50$  mm,  $L = 80$  mm,  $t = 1$  mm,  $\rho_1 = 0.5 \Omega\text{m}$ ,  $V_s = 5\text{V}$ ,  $x_1 = 20$  mm,  $x_2 = 45$  mm,  $y_1 = 30$  mm,  $y_2 = 60$  mm.

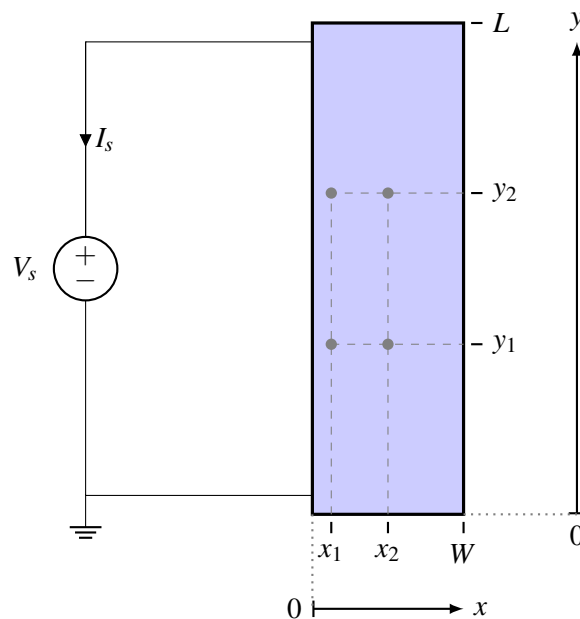

Figure 3: Top view of resistive touchscreen (not to scale).  $z$  axis i.e. the thickness not shown (into the page).

- Draw a circuit diagram representing Figure 3, where the touchscreen is represented as a resistor. **Note that no touch is occurring in this scenario.** Remember that circuit diagrams in general consist of only circuit elements (resistors, sources, etc) represented by symbols, connecting wires, and the reference/ground symbol. Calculate the value of current  $I_s$  based on the circuit diagram you drew. Do not forget to specify the correct unit as always.
- Let us assume  $u_{12}$  is the node voltage at the node represented by coordinates  $(x_1, y_2)$  of the touchscreen, as shown in Figure 4. What is the value of  $u_{12}$ ? You should first draw a circuit diagram representing Figure 4, which includes node  $u_{12}$ . Specify all resistance values in the diagram. Does the value of  $u_{12}$  change based on the value of the  $x$ -coordinate  $x_1$ ?

*Hint: You will need more than one resistor to represent this scenario.*

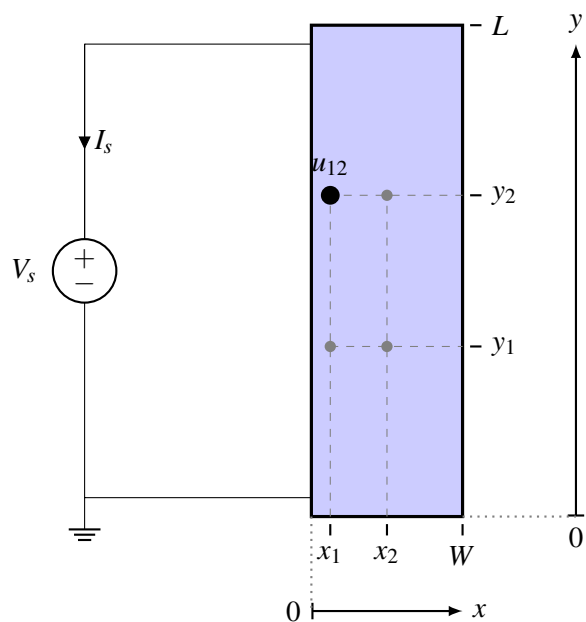

Figure 4: Top view of resistive touchscreen showing node  $u_{12}$ .

- (c) Assume  $V_{ab}$  is the voltage measured between the nodes represented by touchscreen coordinates  $(x_1, y_1)$  and coordinates  $(x_1, y_2)$ , as shown in Figure 5. Calculate the absolute value of  $V_{ab}$ . As with the previous part, you should first draw the circuit diagram representing Figure 5, which includes  $V_{ab}$ . Calculate all resistor values in the circuit. *Hint: Try representing the segment of the touchscreen between these two coordinates as a separate resistor itself.*

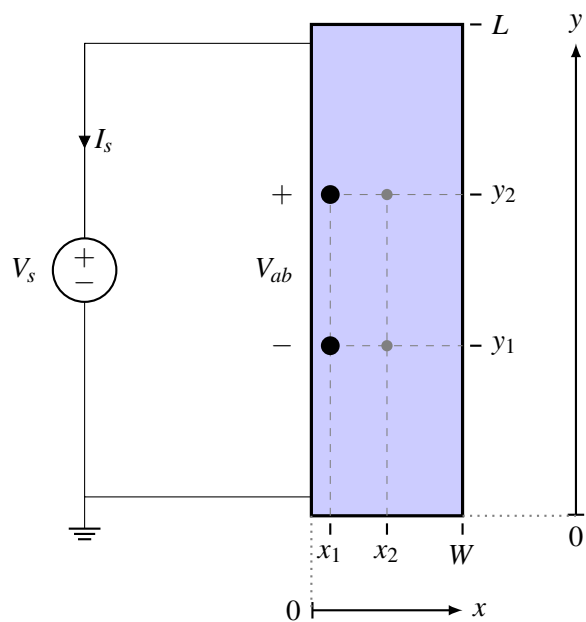

Figure 5: Top view of resistive touchscreen showing voltage  $V_{ab}$ .

- (d) Calculate (the absolute value of) the voltage between the nodes represented by touchscreen coordinates  $(x_1, y_1)$  and coordinates  $(x_2, y_1)$ .
- (e) Calculate (the absolute value of) the voltage between the nodes represented by touchscreen coordinates  $(x_1, y_1)$  and coordinates  $(x_2, y_2)$ .

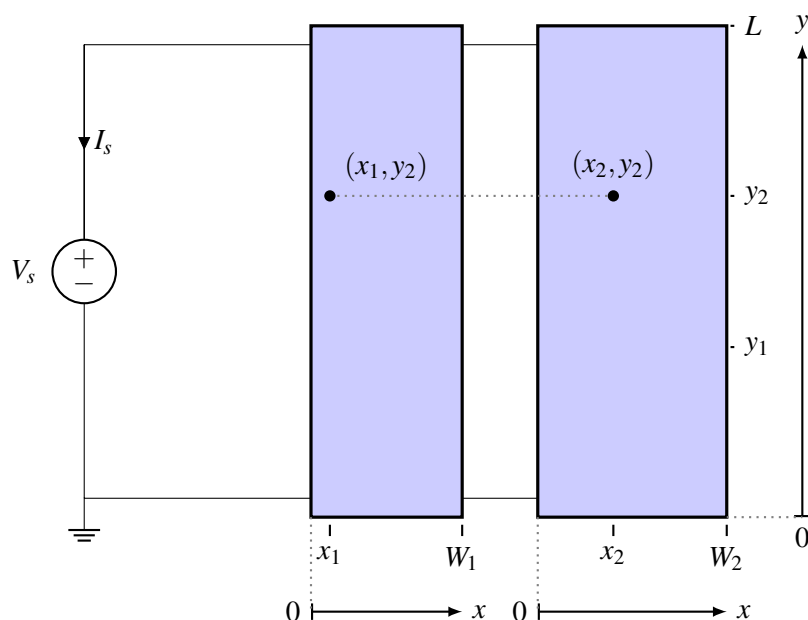

Figure 6: Top view of two touchscreens wired in parallel (not to scale).  $z$  axis not shown (into the page).

- (f) Figure 6 shows a new arrangement with two touchscreens. The two touchscreens are next to each other and are connected to the voltage source in the same way. The second touchscreen (the one on the right) is identical to the one shown in Figure 3, except for different width,  $W_2$ , and resistivity,  $\rho_2$ .

Use the following numerical values in your calculations:  $W_1 = 50$  mm,  $L = 80$  mm,  $t = 1$  mm,  $\rho_1 = 0.5 \Omega\text{m}$ ,  $V_s = 5\text{V}$ ,  $x_1 = 20$  mm,  $x_2 = 45$  mm,  $y_1 = 30$  mm,  $y_2 = 60$  mm, which are the same values as before. The new touchscreen has the following numerical values which are different:  $W_2 = 85$  mm,  $\rho_2 = 0.6 \Omega\text{m}$ .

Draw a circuit diagram representing Figure 6, where the two touchscreens are represented as *two separate resistors*. **Note that no touch is occurring in this scenario.**

- (g) Calculate the value of current  $I_s$  for the two touchscreen arrangement based on the circuit diagram you drew in the last part.
- (h) Consider the two points:  $(x_1, y_2)$  in the touchscreen on the left, and  $(x_2, y_2)$  in the touchscreen on the right in Figure 6. Show that the node voltage at  $(x_1, y_2)$  is the same that at  $(x_2, y_2)$ , i.e. the potential difference between the two points is 0. You can show this without explicitly calculating the node voltages at the two points.
- If you were to connect a wire between the two coordinates  $(x_1, y_2)$  in the touchscreen on the left, and  $(x_2, y_2)$  in the touchscreen on the right, would any current flow through this wire?

## 8. Homework Process and Study Group

Who did you work with on this homework? List names and student ID's. (In case you met people at homework party or in office hours, you can also just describe the group.) How did you work on this homework? If you worked in your study group, explain what role each student played for the meetings this week.